

Selection method of S·N Series

In the use of an universal joint, many factors such as rotating speed, angle, torque and lubrication must be considered. The following selection method shows that, firstly, it is checked the total multiplied value of rotating speed, angle and torque is not exceeding the allowable conditional variable shown in each selection table. Secondly, it is checked that each value of the above three factors does not exceed the allowable value each.

1. Conditional variable

(Calculation formula)

$$\text{Calculation conditional variable} = \text{Rotating speed (min}^{-1}\text{)} \times \text{angle (}^\circ\text{)} \times \text{torque (N.m)}$$

Calculation conditional variable < Allowable conditional variable

2. Rotating speed (min⁻¹)

Rotating speed × angle coefficient < Allowable rotating speed

Angle coefficient table

Angle	5°and Under	10°	15°	20°	25°	30°
Angle coefficient	1.00	1.05	1.18	1.43	1.82	2.50

3. Angle (°)

Angle < Allowable operating angle

4. Torque (N.m)

Torque < Allowable torque

Reference

1. Conversion to International System of Units (SI)

Quantity	Gravitational unit	SI unit
Torque	1kgf.m	9.8 N.m
Force	1kgf	9.8 N

2. Calculation formula by SI unit

Relation between torque, transmission capacity and rotating speed

$$T = 60000 \times P / 2\pi n$$

T : Torque (N.m)

P : Transmission capacity (KW)

n : Rotating speed (min⁻¹)

SC Series Selection table

Item Name	Allowable conditional variable	Allowable rotating speed (min ⁻¹)	Allowable operating angle(°)	Allowable torque(N.m)	Static breaking torque(N.m)	Static tensile load(N)	GD ² (kg.cm ²)	Weight (g)
SC-03-00A	8000	4000	30	0.13	0.4	680	0.001	5
SC-04-00A	13000	3300	30	0.96	2.9	1200	0.003	8
SC-05-00A	21000	2800	30	3.23	9.8	2000	0.007	12
SC-06- **	32000	2500	30	5.3	16	5300	0.015	15
SC-08- **	48000	2200	30	11.6	35	7840	0.044	30
SC-10- **	80000	2000	30	27.4	83	13000	0.13	55
SC-12- **	121000	1800	30	46	140	23000	0.35	110
SC-14- **	151000	1600	30	66	200	26000	0.67	155
SC-16- **	200000	1400	30	102	310	39000	1.5	260
SC-18- **	232000	1200	30	132	400	44000	2.3	345
SC-20- **	273000	1000	30	175	530	52000	3.6	465
SC-22- **	344000	900	30	251	760	68000	5.9	630
SC-25- **	406000	800	30	330	1000	81000	9.7	790
SC-30- **	531000	700	30	495	1500	100000	20	1160
SC-35- **	711000	600	30	792	2400	140000	41	2255
SC-40- **	918000	500	30	1188	3600	180000	77	2730
SC-45- **	1150000	400	30	1584	4800	220000	130	4350
SC-50- **	1400000	300	30	1914	5800	280000	220	5200

Angle	5°and Under	10°	15°	20°	25°	30°
Angle coefficient	1.00	1.05	1.18	1.43	1.82	2.50

Selection example

When SC series is to be used under a rotating speed of 800min⁻¹, an operating angle 15°, and a transmission torque of 10 N.m, the calculation conditional variable 120000 is obtained from the following formula.

$$\text{Rotating speed} \times \text{angle} \times \text{torque} = \text{Conditional variable}$$

$$800 \times 15 \times 10 = 120000$$

Secondly, check the allowable rotating speed of SC-12 according to the following formula.

$$\text{Rotating speed} \times \text{angle coefficient} < \text{Allowable rotating speed}$$

Do the above calculations and compare the allowable conditions to each of the items for SC-12.

1. Conditional variable $\text{—————} 120000 < \text{Allowable conditional variable} \text{—————} 121000$
2. Rotating speed $\text{—————} 800\text{min}^{-1} \times 1.18 < \text{Allowable rotating speed} \text{—————} 1800\text{min}^{-1}$
3. Angle $\text{—————} 15^\circ < \text{Allowable operating angle} \text{—————} 30^\circ$
4. Torque $\text{—————} 10\text{N.m} < \text{Allowable torque} \text{—————} 46\text{N.m}$

The universal joint meeting the requirements of the above service conditions, with good lubricating conditions, is the SC-12.

SC High precision standard top type

JIS B1454 C type

SC-**-00A

(3 to 50mm diam.)

Accessories

Heavy duty set pin 2 pcs.

Ring spring 2 pcs.

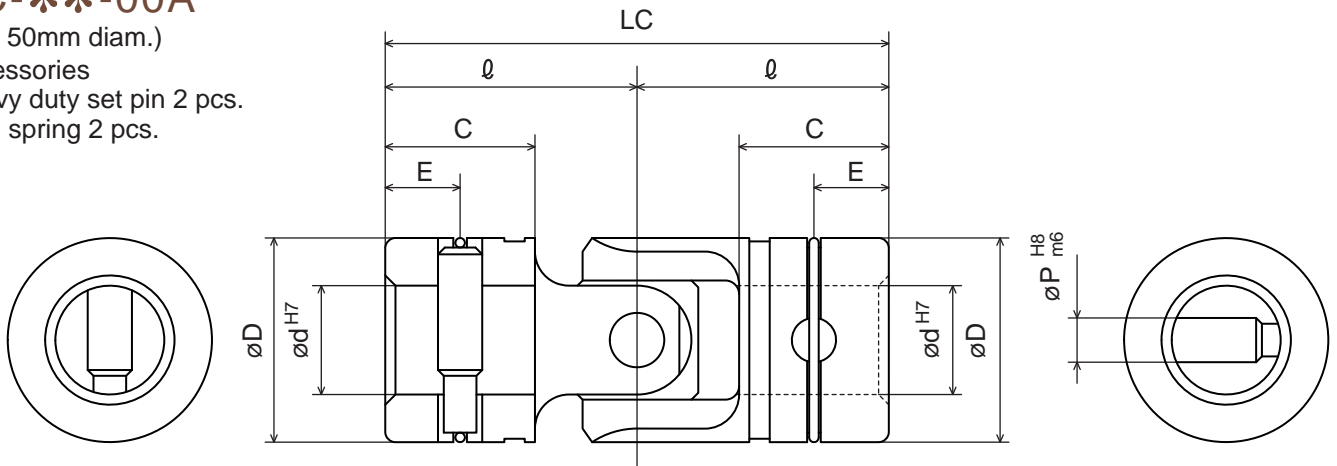

SC-**-03A (New JIS key)

(6 to 50mm diam.)

Accessories

Heavy duty set pin 1 pc.

Ring spring 1 pc.

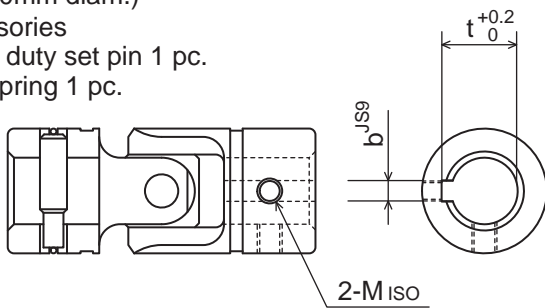

SC-**-33A (New JIS key)

(6 to 50mm diam.)

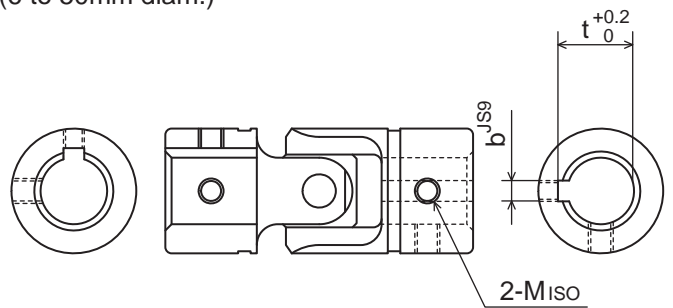

Dimension Name	d	D	LC	l	C	E	P	b	t	b 8	t 8	M	KC
SC-03-00A	3	6	26	13	9	2.5	1	—	—	—	—	—	—
SC-04-00A	4	8	24	12	7	4	1.5	—	—	—	—	—	—
SC-05-00A	5	10	30	15	9	5	2	—	—	—	—	—	—
SC-06- **A	6	12	31	15.5	9	4.5	3	—	—	—	—	3	—
SC-08- **A	8	15	36	18	10	5	3.5	—	—	—	—	3	25
SC-10- **A	10	19	42	21	12	6	4.5	3	11.4	4	11.5	5	32
SC-12- **A	12	23	52	26	15	7.5	5	4	13.8	4	13.5	5	35
SC-14- **A	14	26	59	29.5	17	8.5	5.8	5	16.3	5	16	6	40
SC-16- **A	16	30	74	37	22	11	6.5	5	18.3	5	18	6	46
SC-18- **A	18	33	81	40.5	23.5	11.75	7	6	20.8	5	20	6	52
SC-20- **A	20	36	87	43.5	25	12.5	8	6	22.8	5	22	6	58
SC-22- **A	22	40	94	47	27	13.5	9	6	24.8	7	25	6	62
SC-25- **A	25	44	105	52.5	30	15	10	8	28.3	7	28	8	68
SC-30- **A	30	51	122	61	35	17.5	11.5	8	33.3	7	33	8	82
SC-35- **A	35	59	140	70	40	20	13	10	38.3	10	38.5	10	90
SC-40- **A	40	67	157	78.5	45	22.5	14.5	12	43.3	10	43.5	10	100
SC-45- **A	45	75	176	88	50	25	16	14	48.8	12	48.5	10	110
SC-50- **A	50	83	191	95.5	55	27.5	17.5	14	53.8	12	53.5	10	120

SC-**-08A

(10 to 50mm diam.)

Accessories

Heavy duty set pin 1 pc.

Ring spring 2 pcs.

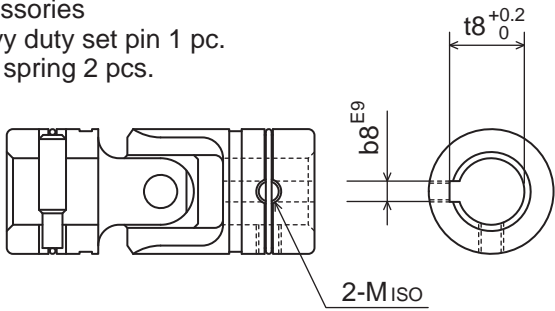

SC-**-88A

(10 to 50mm diam.)

Accessories

Ring spring 2 pcs.

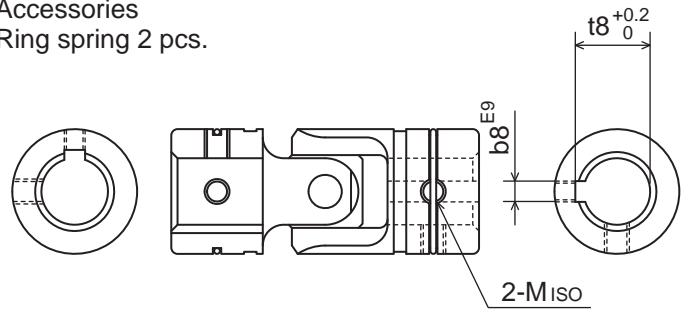

GBC**-00

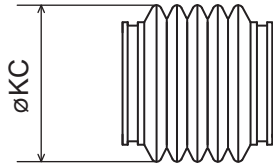

When the rubber cover to be attached is required, denote SC-**-**C. SC-08~30 size is set with rubber cover and grease is sealed. SC-35~50 is attached with special below (accessory). Quick change type is not available with rubber cover.

SC-**-09A (Quick change type)

(8 to 30mm diam.)

Accessories

Heavy duty set pin 1 pc.

Ring spring 1 pc.

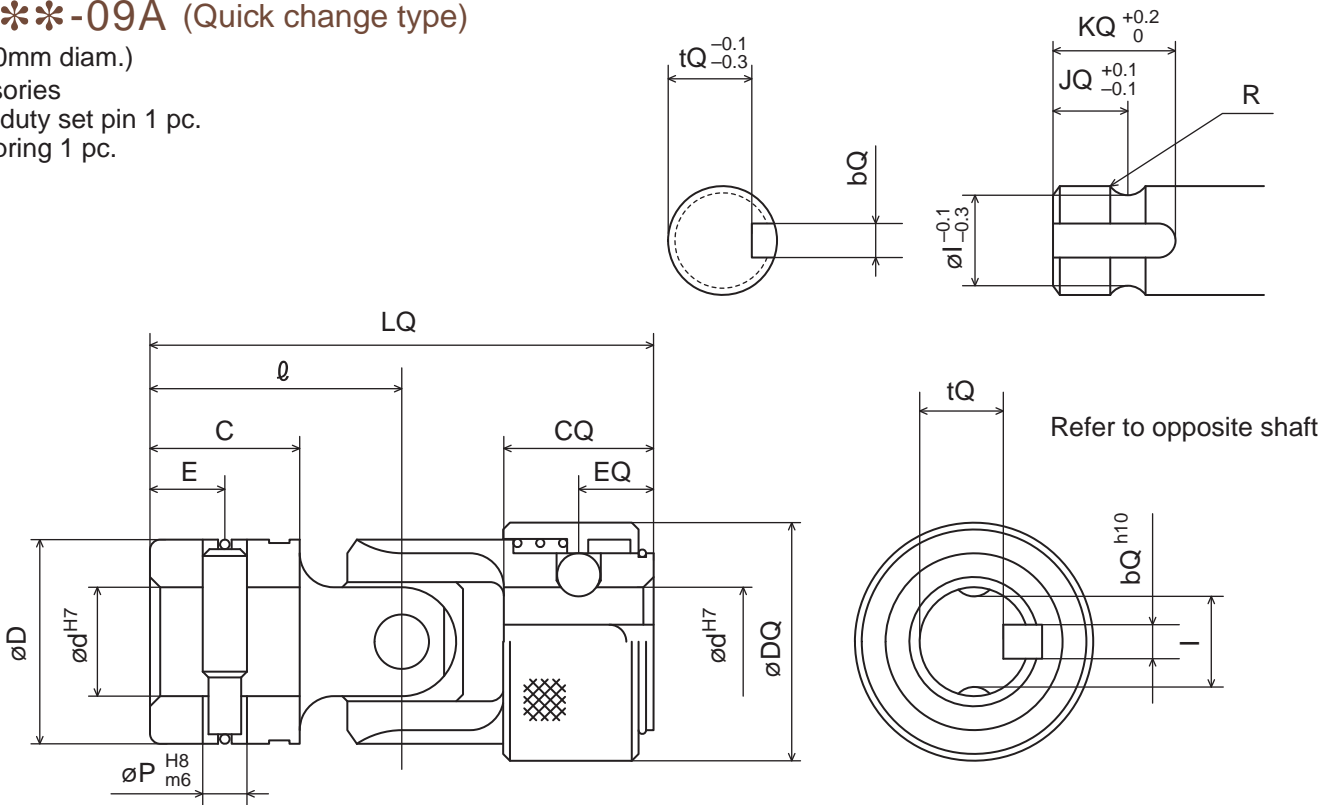

Dimension Name	d	D	LQ	\varnothing	C	E	P	DQ	CQ	EQ	I	R	JQ	bQ	tQ	KQ
SC-08-09A	8	15	38	18	10	5	3.5	19	12	4	6.56	2	8	3	5.8	10
SC-10-09A	10	19	42	21	12	6	4.5	21.5	12	4	9.06	2	8	4	7.5	9
SC-12-09A	12	23	52	26	15	7.5	5	23.8	15	7.5	10.48	2.4	7.5	4	8.8	12
SC-14-09A	14	26	59	29.5	17	8.5	5.8	29	17	8.5	11.88	2.8	8.5	5	10.3	14
SC-16-09A	16	30	74	37	22	11	6.5	35	22	11	13.3	3.2	11	5	12.3	18
SC-18-09A	18	33	81	40.5	23.5	11.75	7	38	23.5	11.75	15.3	3.2	11.75	5	14.5	21
SC-20-09A	20	36	87	43.5	25	12.5	8	42	25	12.5	17.12	4	12.5	6	16.0	23
SC-22-09A	22	40	94	47	27	13.5	9	44	27	13.5	19.12	4	13.5	6	17.8	25
SC-25-09A	25	44	105	52.5	30	15	10	49	30	15	21.54	4.4	15	7	21	28
SC-30-09A	30	51	122	61	35	17.5	11.5	56	35	17.5	26.95	4.8	17.5	7	25.3	30

SD Series Selection table

Item Name	Allowable conditional variable	Allowable rotating speed (min ⁻¹)	Allowable operating angle(°)	Allowable torque(N.m)	Static breaking torque(N.m)	Static tensile load(N)	GD ² (kg.cm ²)	Weight (g)
SD-06- **	32000	2500	one side 30	3.96	12	5300	0.029	30
SD-08- **	48000	2200	one side 30	8.58	26	7840	0.069	50
SD-10- **	80000	2000	one side 30	20.1	61	13000	0.21	95
SD-12- **	121000	1800	one side 30	33	100	23000	0.55	180
SD-14- **	151000	1600	one side 30	46	140	26000	1.0	250
SD-16- **	200000	1400	one side 30	76	230	39000	2.3	410
SD-18- **	232000	1200	one side 30	96	290	44000	3.7	550
SD-20- **	273000	1000	one side 30	129	390	52000	5.7	690
SD-22- **	344000	900	one side 30	185	560	68000	9.1	940
SD-25- **	406000	800	one side 30	248	750	81000	15	1240
SD-30- **	531000	700	one side 30	363	1100	100000	31	1775
SD-35- **	711000	600	one side 30	594	1800	140000	75	3180
SD-40- **	918000	500	one side 30	891	2700	180000	120	4150
SD-45- **	1150000	400	one side 30	1155	3500	220000	210	6225
SD-50- **	1400000	300	one side 30	1419	4300	280000	340	7750

Angle	5°and Under	10°	15°	20°	25°	30°
Angle coefficient	1.00	1.05	1.18	1.43	1.82	2.50

Selection example

When SD series is to be used under a rotating speed of 300min⁻¹, an operating angle 10°, and a transmission torque of 88 N.m, the calculation conditional variable 264000 is obtained from the following formula.

$$\text{Rotating speed} \times \text{angle} \times \text{torque} = \text{Conditional variable}$$

$$300 \times 10 \times 88 = 264000$$

Secondly, check the allowable rotating speed of SD-20 according to the following formula.

$$\text{Rotating speed} \times \text{angle coefficient} < \text{Allowable rotating speed}$$

Do the above calculations and compare the allowable conditions to each of the items for SD-20.

1. Conditional variable _____ 264000 < Allowable conditional variable _____ 273000
2. Rotating speed _____ 300min⁻¹ × 1.05 < Allowable rotating speed _____ 1000min⁻¹
3. Angle _____ 10° < Allowable operating angle _____ 30°
4. Torque _____ 88N.m < Allowable torque _____ 129N.m

The universal joint meeting the requirements of the above service conditions, with good lubricating conditions, is the SD-20.

SD High precision standard top type

JIS B1454 CC type

SD-**-00A

(6 to 50mm diam.)
Accessories
Heavy duty set pin
2 pcs.
Ring spring 2 pcs.

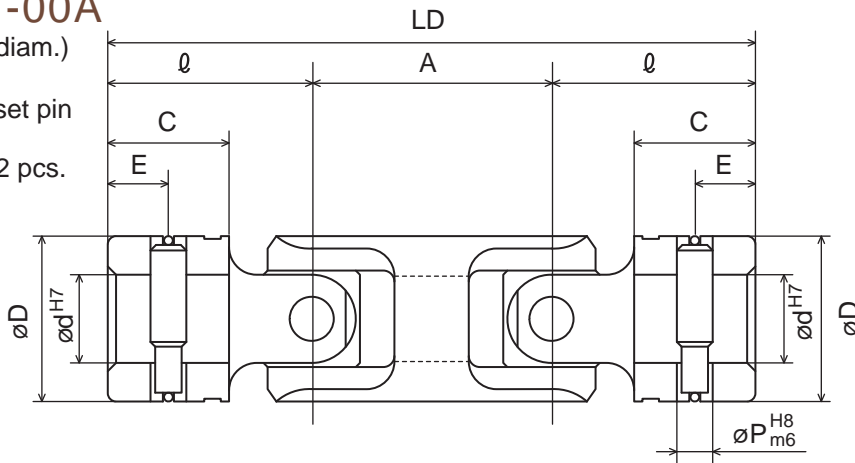

GBD**-00

If attached rubber cover is required for use, denote SD-**-**C beforehand. SD-08~30 size is set with rubber cover and grease is sealed. SD-35~50 size is attached with special bellow (accessory).

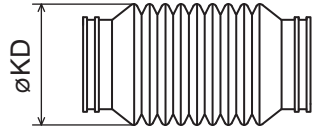

SD-**-03A (New JIS key)

(6 to 50mm diam.)
Accessories Heavy duty set pin 1 pc.
Ring spring 1 pc.

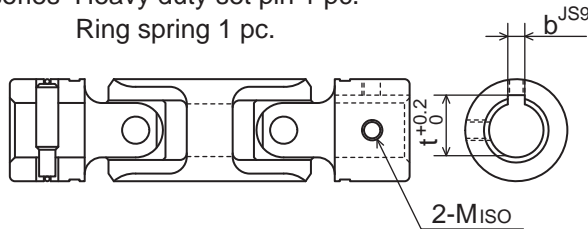

SD-**-33A (New JIS key)

(6 to 50mm diam.)

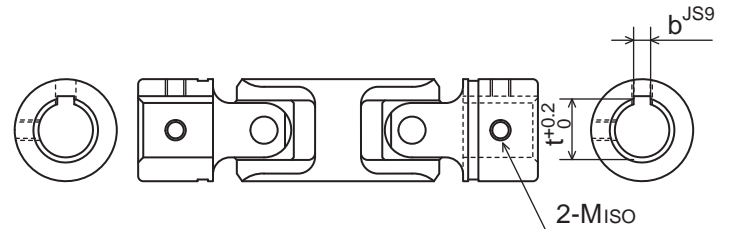

SD-**-08A

(10 to 50mm diam.)
Accessories Heavy duty set pin 1 pc. Ring spring 2 pcs.

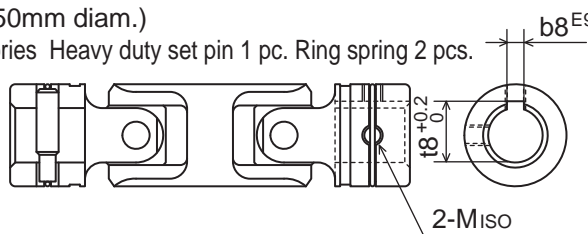

SD-**-88A

(10 to 50mm diam.)
Accessories Ring spring 2 pcs.

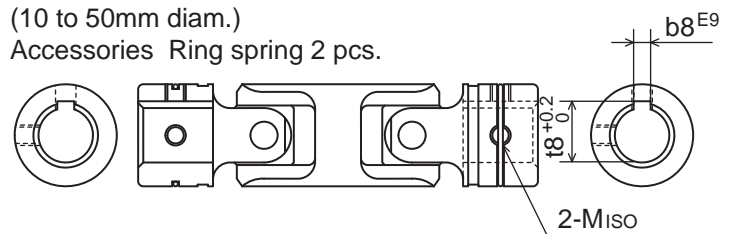

Dimension Name	d	D	LD	A	ϕ	C	E	P	b	t	b8	t8	M	KD
SD-06- **A	6	12	49.5	18.5	15.5	9	4.5	3	—	—	—	—	3	—
SD-08- **A	8	15	58	22	18	10	5	3.5	—	—	—	—	3	26
SD-10- **A	10	19	67.5	25.5	21	12	6	4.5	3	11.4	4	11.5	5	32
SD-12- **A	12	23	83	31	26	15	7.5	5	4	13.8	4	13.5	5	36
SD-14- **A	14	26	94.5	35.5	29.5	17	8.5	5.8	5	16.3	5	16	6	40
SD-16- **A	16	30	117.5	43.5	37	22	11	6.5	5	18.3	5	18	6	46
SD-18- **A	18	33	129	48	40.5	23.5	11.75	7	6	20.8	5	20	6	52
SD-20- **A	20	36	139	52	43.5	25	12.5	8	6	22.8	5	22	6	58
SD-22- **A	22	40	150	56	47	27	13.5	9	6	24.8	7	25	6	62
SD-25- **A	25	44	168	63	52.5	30	15	10	8	28.3	7	28	8	68
SD-30- **A	30	51	195	73	61	35	17.5	11.5	8	33.3	7	33	8	82
SD-35- **A	35	59	224	84	70	40	20	13	10	38.3	10	38.5	10	90
SD-40- **A	40	67	251	94	78.5	45	22.5	14.5	12	43.3	10	43.5	10	100
SD-45- **A	45	75	282	106	88	50	25	16	14	48.8	12	48.5	10	110
SD-50- **A	50	83	304	113	95.5	55	27.5	17.5	14	53.8	12	53.5	10	120

SP TYPE With intermediate spline

SP-**-00A

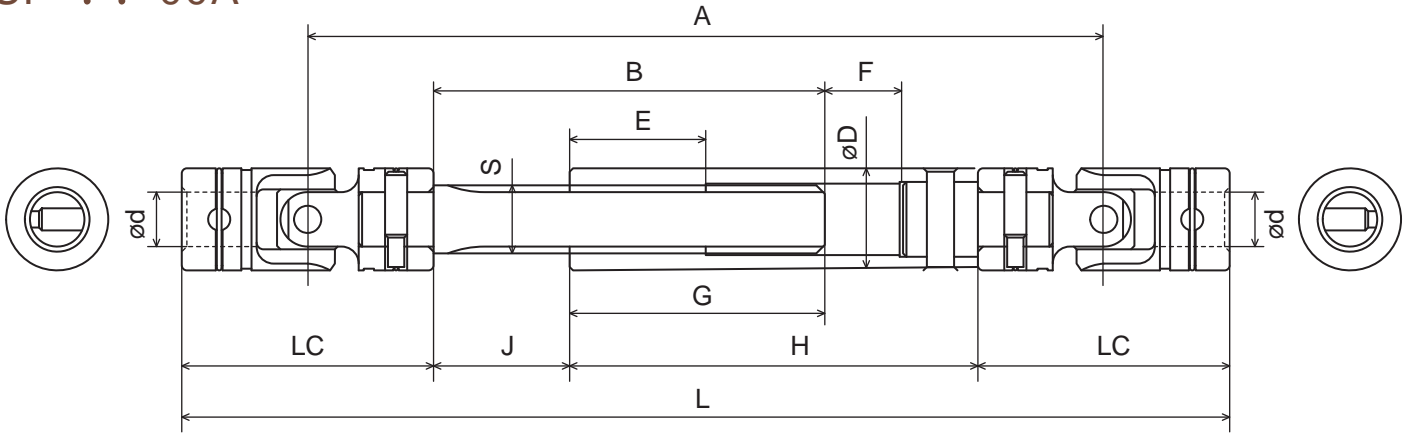

SP-**-03A (New JIS key)

SP-**-33A (New JIS key)

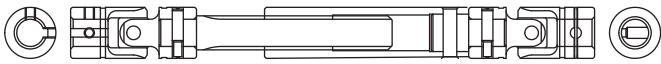

SP-**-08A

SP-**-88A

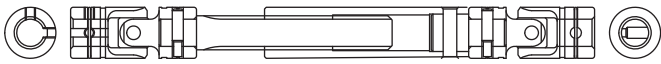

SP-**-09A

SP-**-99A



AS per out of standard items, inquire us with detailed specification or show us a schematic drawing.

Dimension Name	d	L	Telescopic section	A	B	Spline item S	E	LC	LQ	D	F	G	H	J
SP-08- **A	8	163	+19 -11	127	65	INVOLUTE Diameter=10 m=0.75 z=11	20	36	—	17	11	39	65	26
SP-08- 09A	8	167	+17 -13	129	65	INVOLUTE Diameter=10 m=0.75 z=11	20	36	38	17	13	37	65	28
SP-08- 99A	8	169	+17 -13	129	65	INVOLUTE Diameter=10 m=0.75 z=11	20	—	38	17	13	37	65	28
SP-10- **A	10	177	+17 -13	135	65	INVOLUTE Diameter=12 m=1.0 z=10	25	42	42	19	13	37	65	28
SP-12- **A	12	225	+16 -16	173	88	16 × 13 × 3.5-6	40	52	52	23	16	56	89	32
SP-14- **A	14	240	+14 -18	181	87	16 × 13 × 3.5-6	40	59	59	23	18	54	89	33
SP-16- **A	16	308	+35 -23	234	115	20 × 16 × 4-6	40	74	74	30	23	75	120	40
SP-18- **A	18	327	+30 -26	246	115	20 × 16 × 4-6	40	81	81	30	28	70	120	45
SP-20- **A	20	344	+33 -27	257	118	22 × 18 × 5-6	40	87	87	36	27	73	125	45
SP-22- **A	22	360	+28 -30	266	115	25 × 21 × 5-6	40	94	94	40	30	68	125	47
SP-25- **A	25	405	+38 -32	300	133	28 × 23 × 6-6	45	105	105	44	32	83	145	50
SP-30- **A	30	464	+35 -40	342	145	32 × 26 × 6-6	50	122	122	51	40	85	160	60
SP-35- **A	35	515	+35 -45	375	150	38 × 32 × 8-6	50	140	—	60	45	85	170	65
SP-40- **A	40	574	+35 -50	417	165	42 × 36 × 8-6	60	157	—	67	50	95	190	70
SP-45- **A	45	637	+35 -55	461	180	45 × 41 × 8-8	70	176	—	75	55	105	210	75
SP-50- **A	50	697	+35 -60	506	200	52 × 46 × 9-8	80	191	—	83	60	115	230	85