

HJ TYPE Cold-Forged Steering Joint

Yoke Welded Standard Dimensions

HCY1R

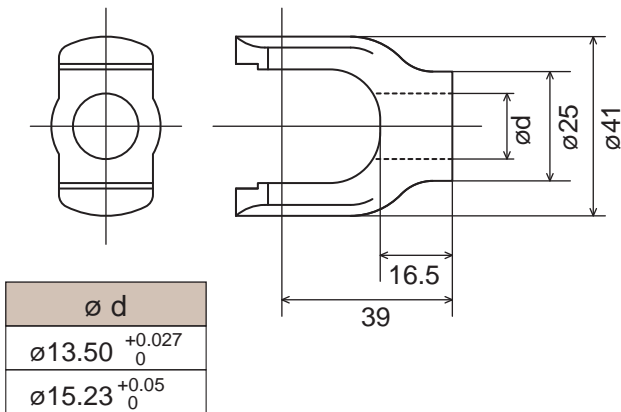

HCY4R

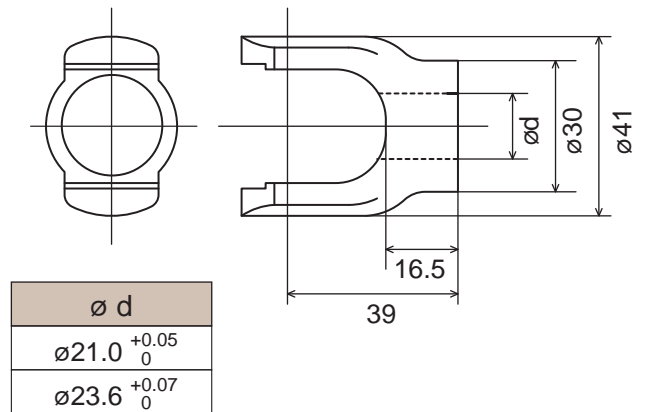

Note ; The dimensions are our standard of forged yoke. Please be sure to inquire us for assembling or combination of the yokes. The shaft and welded yoke are combined by welding or pins.

Yoke Bolts Standard Specifications

HCY1B

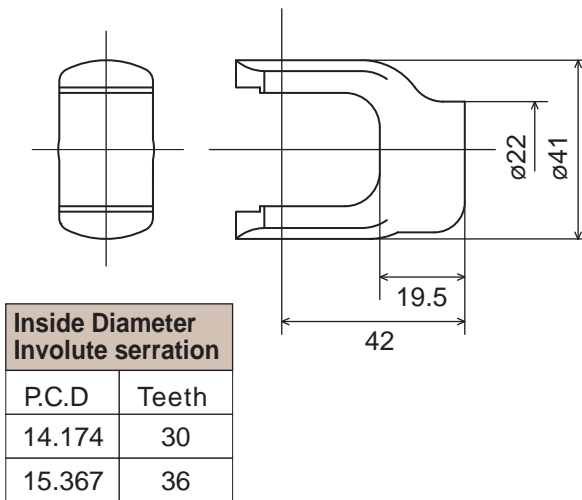

HCY4B

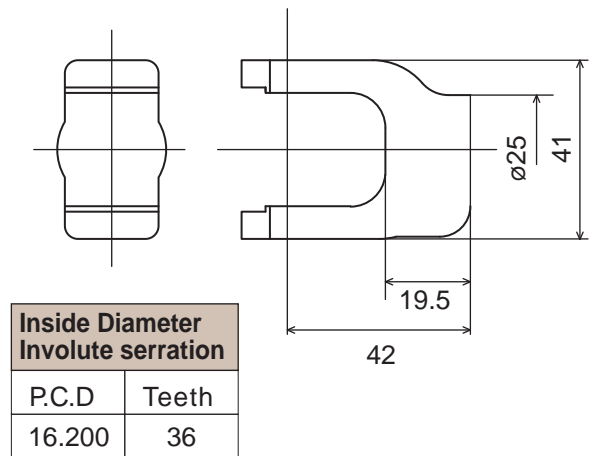

HCY3B

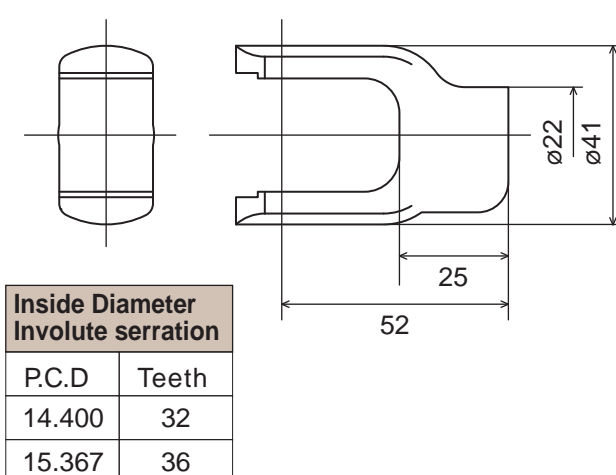

HCY6B

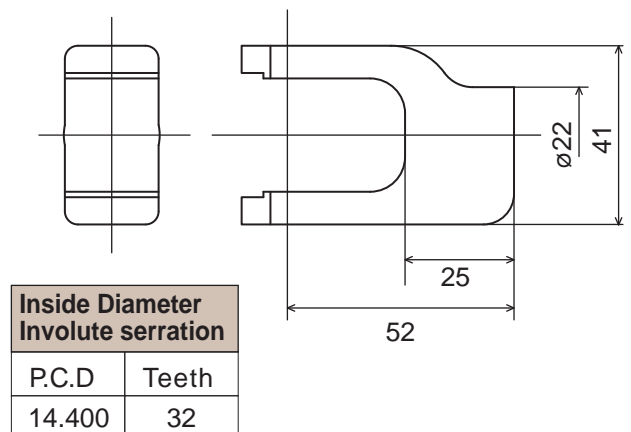

Yoke Bolts (High Rigidity & Wide Angle)



Combination Examples of Yoke Bolts



Combination of Yoke Bolts



Combination of Yoke Bolts



Combination of Yoke Bolts



Extention

- Note ;
1. Use locking bolt for bolt yoke of not less than strength section 7T.
 2. Apply 20N.m to bolt locking torque.
 3. Use welding or pin to connect shaft and round yoke.
 4. Be sure to inquire about combination, as the specifications shown in this catalog are.
Kyowa's basic specifications.